

RFM220 ISDB-Tb Measurement Demodulator



Features & Benefits

- Comprehensive ISDB-Tb RF measurement and monitoring capabilities including overall and separate MER per layer (one for HDTV, one for the 1-seg), TMCC information monitoring, and Channel Impulse Response display with SFN window measurements plus Constellation and Spectrum displays with shoulder measurements help to identify degradations in transmitter performance and efficiency before viewers are impacted
- High-performance tuner/demodulator with MER measurement performance to 36 dB typ. offers the flexibility needed for use in both transmitter monitoring and off-air ISDB-Tb broadcast applications
- Remote access to monitoring functionality with user-configurable alarm reporting, event logs, and 7-day trending enables remote notification and reporting to engineers and operators of transmission system problems
- Transport Stream output enables connection to MPEG TS monitoring systems, including Tektronix MTM400A or Sentry products, offering a flexible and affordable monitoring solution to quickly identify and isolate problems in either the Transport Stream or the RF signal

Applications

- RF performance monitoring of local and remote ISDB-Tb transmitter sites
- Off-air monitoring at local and national operation centers and headends

Introduction

The RFM220 is a measurement demodulator for broadcast network operators who deploy and maintain ISDB-Tb broadcast networks by providing remote monitoring of all key ISDB-Tb broadcast RF parameters, with 7-day long-term trending, high-performance diagnostic RF capabilities, and event logging for unattended operation. Product specification summary is shown below:

- RF Specs
 - Frequency: 170-230 MHz / 470-862 MHz
 - Bandwidth: 6 MHz
 - Input Sensitivity: -30 dBm / -90 dBm
 - Max Input Level: 0 dBm
- RF Measurements
 - Input Level: -50 dBm to -30 dBm
 - Resolution: 0.1 dB
 - Accuracy: <2 dB typ.
 - MER (with individual MER for both layers): 28 dB to 36 dB typ., Resolution 0.1 dB Accuracy ± 1.5 dB
 - SNR
 - BER (post Viterbi / pre RS)
 - PER (Uncorrected packet post RS)
 - Carrier Frequency Offset (CFO)
 - Left and Right Shoulder Attenuation
- Measurement Displays
 - TMCC Data Display
 - Channel Impulse Response (Delay Profile) with 5 main echoes in SFN window
 - Constellation Display (merged and individual layer)
 - Spectrum Display
- Other
 - Remote Web Access and Control
 - SNMP Traps for 3rd-party Management Systems
 - Demodulated ASI Output
 - ASI Input

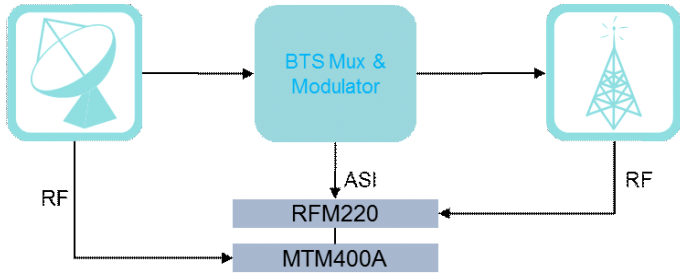

Combined RF and TS Monitoring.

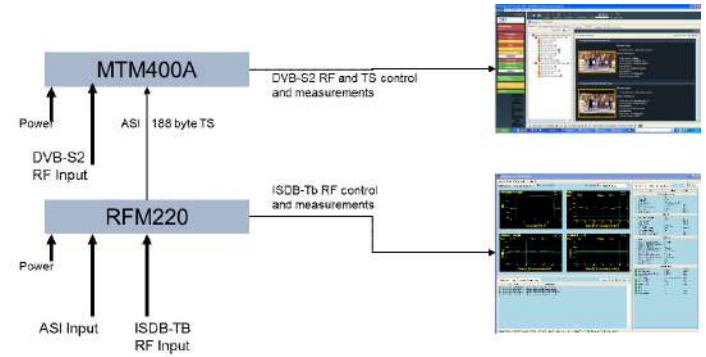

MTM400A with DVB-S2 Measurement Interface and RFM220 Measurement Demodulator.

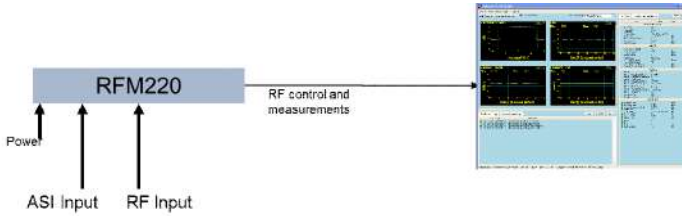

RFM220 Measurement Demodulator with RF Monitoring Remote Interface.

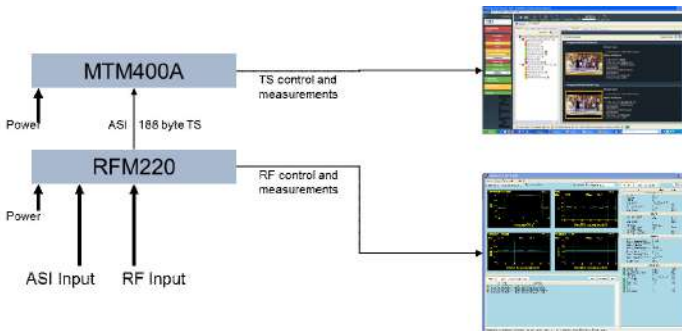

MTM400A with RFM220 Measurement Demodulator and both RF and TS Remote User Interfaces.

Product Information

The RFM220 product is a 1RU rackmount product that can be used as a stand-alone RF monitoring solution or used in conjunction with an MTM400A to provide combined RF and TS monitoring.

RF and ASI Inputs

A separate UI is provided to present the RFM220 measurements, enabling the user to monitor and analyze both Transport Stream and RF measurements simultaneously.

Both RF and ASI inputs can be connected to the RFM220 and the user can select the source for output to an MTM400A or any other device that requires ASI input. This enables monitoring before and after modulation.

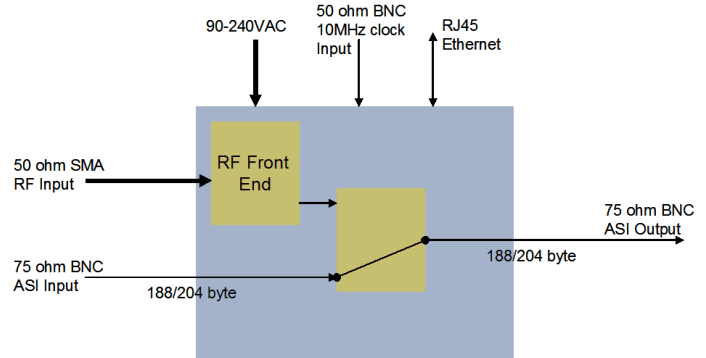

Routing ASI Input.

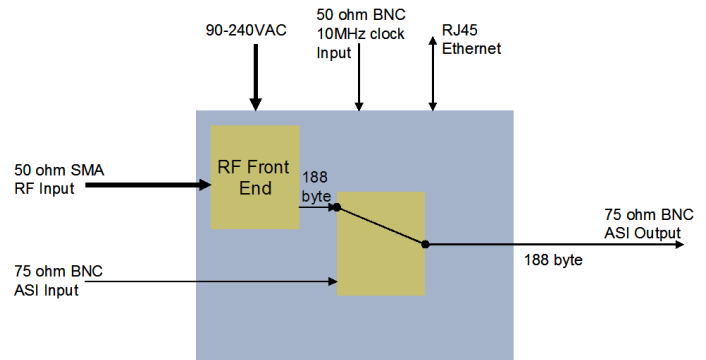

Routing RF Input.

A unique feature of the RFM220 product is that it will continue to monitor the RF signal quality even if the ASI input is selected for routing to the MTM400A for TS analysis. In this configuration a 204-byte BTS input can be monitored providing TMCC and IIP consistency analysis in the MTM400A in addition to monitoring the RF broadcast signal quality.

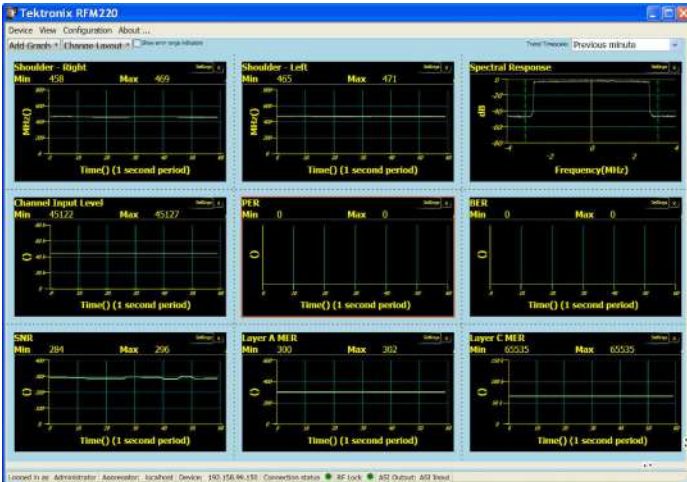

ISDB-Tb RF Remote Monitoring Functionality.

ISDB-Tb RF Remote Monitoring Functionality (Alarms, Event Logs, and 7-day Trending of RF Metrics)

Key RF metrics including Channel Power, Full Band Power, SNR, MER, BER, Packet Error Ratio, and Shoulder Attenuation are monitored, tested, and displayed to enable operators to ensure that their RF systems are operating correctly and that services are available to viewers. Metrics and test results are stored and can be displayed as long-term trends for up to a 7-day history, as event logs for offline viewing, or exported into other tools for analysis and reporting. Remote access enables skilled engineers in broadcasters' main engineering facilities to remotely diagnose problems at regional and local levels without the need to travel.

Overall and/or Separate MER per Layer (One for HDTV, One for the 1-seg)

The ISDB-Tb system provides hierarchical modulation whereby multiple services are broadcast as different layers within the same 6 MHz RF channel. Typically this consists of a low bit rate service using robust QPSK constellation on 1 of the 13 ISDB-Tb broadcast signal segments for mobile and handheld devices plus an HD signal using 64QAM on the other 12 segments. It is important for the operator to know the quality of the RF signal for each service. Products that only provide a single overall MER cannot distinguish between RF degradation issues that are affecting the mobile service and issues that affect the HD service.

MER Measurement Performance to 36 dB Typ.

MER is the key RF transmission metric used by broadcasters to ensure the transmission network is operating properly. High-quality MER measurements are critical to ensure that early indication can be given of transmission problems, enabling action to be taken before viewers'

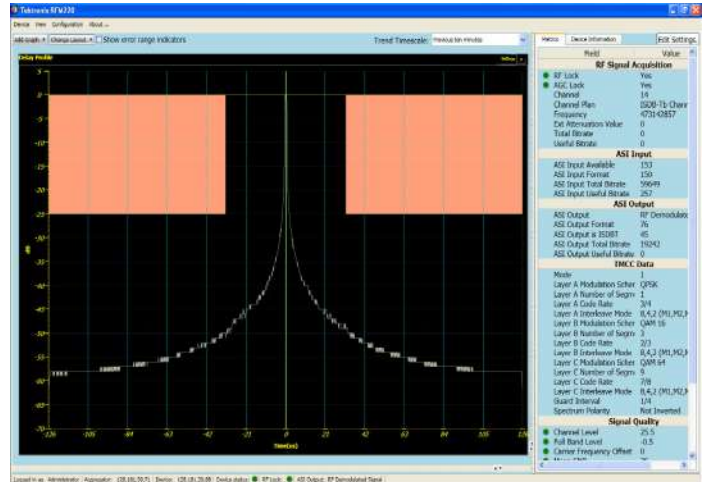

Channel Impulse Response Display and SFN Window Measurements.

reception of the signal is impacted. The quality of the RFM220 MER measurement means it is capable of being used as a remote transmitter monitor that will reliably give early indication of transmission issues, provide long-term trend information to alert operators of gradual degradations of signal quality, and take proactive action to prevent viewers from experiencing problems.

TMCC Information Monitoring

TMCC information must be monitored to ensure that receivers can demodulate the signal effectively. Errors in the TMCC information would lead to STBs not functioning properly. In addition to displaying the TMCC information on the RFM220 user interface, the MTM400A can be used to provide TMCC and IIP consistency testing and analysis at the Transport Stream layer. The in-depth ISDB-Tb cross-table consistency testing is a unique feature developed over many years in conjunction with Japanese broadcasters, and when combined with ISDB-Tb RF metrics the Tektronix solution represents a powerful and unique toolset for remote ISDB-Tb monitoring.

Channel Impulse Response Display and SFN Window Measurements

The RFM220 provides Channel Impulse response graphs, (also known as Channel Delay Profile), over a 2x guard interval to show whether echoes caused by multipath are likely to cause interference problems. The five main echoes are indicated to the user to enable peaks to be easily identified, and the user can determine whether remedial action must be taken. This is particularly important in SFN networks where transmitters must be synchronized so they won't interfere with each other, and the RFM220 displays can be used to remotely detect SFN network timing problems enabling corrections to be made.

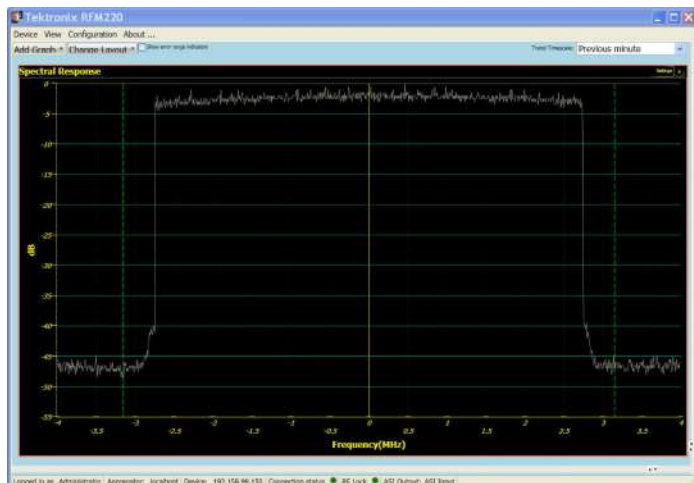

Spectrum Displays with Shoulder Measurements.

Constellation and Spectrum Displays with Shoulder Measurements

The Constellation and Spectrum displays enable engineers to identify modulation problems such as amplitude imbalance, quadrature error, coherent interference, phase noise, amplitude noise, phase error, and MER problems. The left and right shoulder measurements are displayed in dB to help indicate if there are spectrum mask issues.

More information about identification of such problems using these displays is available in the Tektronix application note *Critical RF Measurements in Cable, Satellite, and Terrestrial DTV Systems*.

SNMP Trap Generation

The RFM220 monitoring system provides SNMP trap generation when tests fail, enabling the RF monitoring solution to provide notification to network management systems for operational alerting and reporting.

Characteristics

RF

Characteristic	Description
RF Standard	ISDB-Tb
RF Input Connector	N type – 50 Ω
RF Input Frequency Range	VHF: 170 MHz to 230 MHz UHF: 470 MHz to 862 MHz
Frequency Offset Recovery	±340 kHz
Channel Bandwidth	6 MHz
Input Signal Amplitude Range	-90 dBm to -30 dBm for a BER of $1e^{-4}$ -50 dBm to -30 dBm for best measurement performance 0 dBm max to avoid damage -50 dBm to -30 dBm for MER up to 36 dB -90 dBm to -30 dBm for MER to 28 dB max
Noise Figure	12 dB
Return Loss	>13 dB
Adjacent Channel Rejection	Analog: >35 dB Digital: >30 dB
Demodulation Format	ISDB-Tb, all modes, layers 1, 2, or 3

Measurements

Characteristic	Description
Full Band Input Level	-50 dBm to -10 dBm Resolution: 0.1 dB
Channel Input Level	-90 dBm to -30 dBm Resolution: 0.1 dB
MER (Modulation Error Ratio) with Equalizer (Fine Mode)	Display Range: 28 dB to at least 36 dB for input level from -50 dBm to -30 dBm (for best measurement, coarse MER displays lower MER) Resolution: 0.1 dB
C/N (Carrier to Noise Ratio)	Display Range: 0 dB to 28 dB for -50 dBm to -30 dBm input level Resolution: 1 dB
BER at Viterbi Output Accuracy (Pre Reed Solomon)	1/10 ⁸
PER (Packet Error Rate) Accuracy	1/frame
Constellation Display	1024 points
SFN Window	5 main echoes (relative delay and level)
Channel Impulse Response Display	2560 points at 256 scale
Spectrum Display	2048 points at 256 scale
Left and Right Shoulders	44 dB max Resolution: 0.1 dB

ASI Input

Characteristic	Description
Format	DVB-ASI Mode: Burst or Continuous (Packet)
Connector	BNC – 75 Ω
Packet Size	188 or 204 bytes
Maximum Useful Bit Rate	50 Mb/s max

ASI Output

Characteristic	Description
Format	DVB-ASI Continuous mode
Connector	BNC – 75 Ω
Mode	Packet mode
Packet Size	188 or 204 bytes (ASI input source) Output format identical to input format
Maximum Useful Bit Rate	50 Mb/s max
Maximum Output Jitter	±100 ms

Control Port

Characteristic	Description
Interface	10/100/1000BASE-T
Connector Type	RJ-45
Packet Type	IPv4
Mode	Half/Full duplex

Clocks and Synchronization

Characteristic	Description
External 10 MHz Reference Input	Connector: BNC – 50 Ω Frequency: 10 MHz Level: 0 to +10 dBm recommended

AC Power Source

Characteristic	Description
Source Voltage	100 to 240 V AC. Fluctuations must not exceed 10% of the nominal rated voltage
Frequency Range	50/60 Hz
Power Consumption	0.25 to 0.60 A maximum, 100 to 240 V, 50/60 Hz, single phase
Peak In-rush Current	1 A peak at 240 V AC, 50 Hz

Mechanical

Characteristic	Description
Cooling Airflow	Intake is from the left side of the instrument, and exhaust is to the right side of the instrument. For proper cooling, at least 51 mm (2 in.) of clearance is needed on both sides of the instrument cabinet

Physical

Dimension	mm	in.
Height	45	1.8
Width (with ears)	495	19.5
Depth	352.2	13.9
Weight	kg	lb.
Net	6.4	14.1
Shipping	9.4	20.7

Environmental

Characteristic	Description
Temperature	Temperature of the intake air at the front and sides of the instrument
Operating	+5 °C to +40 °C, 30 °C/hr max gradient
Nonoperating	-20°C to +60°C, 30°C/hr max gradient
Humidity	
Operating	20% to 80% relative humidity, noncondensing
Nonoperating	10% to 80% relative humidity, noncondensing
Altitude	
Operating	0 to 3000 m (9800 ft.)
Nonoperating	0 to 12,000 m (40,000 ft.)
Random Vibration	
Operating	0.27 G _{RMS} total from 5 Hz to 500 Hz
Nonoperating	2.28 G _{RMS} total from 5 Hz to 500 Hz
Sine Vibration	
Operating	0.013 in. peak-peak displacement, 5 Hz to 55 Hz
Functional Shock	
Nonoperating	30 G, 11 ms half-sine

Transportation and Storage

Characteristic	Description
Transportation Package Material	Transportation package material meets recycling criteria as described in Environmental Guidelines for Package Design (Tektronix 063-1290-00) and Environmentally Responsible Packaging Handbook (Tektronix 063-1302-00)

Certifications and Compliances

Characteristic	Description
Compliance	Tektronix Product: IEC61010-1: 2001. 2nd Edition. Safety requirements for electrical equipment for measurement, control, and laboratory use Product will carry 3rd-party safety marking allowing sale in Brazil.

Ordering Information

RFM220 ISDB-Tb Measurement Demodulator

Includes: 1RU ISDB-Tb Measurement Demodulator, user manual, application CD, Brazil power cord.

Service Options

Option	Description
R3	Repair Service 3 Years (including warranty)
-R3DW	Repair Service Coverage 3 Years (includes product warranty period). 3-year period starts at time of customer instrument purchase

Related Products

Product	Description
MTM400A	DTV Monitor with ISDB-Tb TS and BTS ASI analysis capability and DVB-S2 RF monitoring option
IPM400A	IP Video Diagnostic Monitor with ASI and GbE diagnostic monitoring
QAM400A	DTV Monitor with ASI and ITU J.83 Annex A, B, or C RF diagnostic monitoring
RTX100B ISDB-Tb	RF, ASI, and GbE Test Signal Generator for stream creation, multiplexing, and RF up-conversion/modulation
MTS400 Series	MPEG Test Systems for in-depth capture, analysis, and playout of compressed video signals
VQS1000	Video Quality Test System for real-time video and audio quality monitoring



Tektronix is registered to ISO 9001 and ISO 14001 by SRI Quality System Registrar.

Contact Tektronix:

ASEAN / Australasia (65) 6356 3900
Austria 00800 2255 4835*
Balkans, Israel, South Africa and other ISE Countries +41 52 675 3777
Belgium 00800 2255 4835*
Brazil +55 (11) 3759 7627
Canada 1 800 833 9200
Central East Europe and the Baltics +41 52 675 3777
Central Europe & Greece +41 52 675 3777
Denmark +45 80 88 1401
Finland +41 52 675 3777
France 00800 2255 4835*
Germany 00800 2255 4835*
Hong Kong 400 820 5835
India 000 800 650 1835
Italy 00800 2255 4835*
Japan 81 (3) 6714 3010
Luxembourg +41 52 675 3777
Mexico, Central/South America & Caribbean 52 (55) 56 04 50 90
Middle East, Asia, and North Africa +41 52 675 3777
The Netherlands 00800 2255 4835*
Norway 800 16098
People's Republic of China 400 820 5835
Poland +41 52 675 3777
Portugal 80 08 12370
Republic of Korea 001 800 8255 2835
Russia & CIS +7 (495) 6647564
South Africa +41 52 675 3777
Spain 00800 2255 4835*
Sweden 00800 2255 4835*
Switzerland 00800 2255 4835*
Taiwan 886 (2) 2722 9622
United Kingdom & Ireland 00800 2255 4835*
USA 1 800 833 9200

* European toll-free number. If not accessible, call: +41 52 675 3777

Updated 10 February 2011

For Further Information. Tektronix maintains a comprehensive, constantly expanding collection of application notes, technical briefs and other resources to help engineers working on the cutting edge of technology. Please visit www.tektronix.com



Copyright © Tektronix, Inc. All rights reserved. Tektronix products are covered by U.S. and foreign patents, issued and pending. Information in this publication supersedes that in all previously published material. Specification and price change privileges reserved. TEKTRONIX and TEK are registered trademarks of Tektronix, Inc. All other trade names referenced are the service marks, trademarks, or registered trademarks of their respective companies.

05 Aug 2013

2BW-26825-2

www.tektronix.com



For more information contact us at sales@testforce.com, or call us toll-free at **1(888)880-6804**. www.testforce.com